

YAMAHA SINGLE-AXIS ROBOT

FLIP-X Series

Maintenance Manual

T4L/T4LH/T5L/T5LH/T6L/T9/T9H
F8/F8L/F8LH/F10/F10H/F14/F14H/F17/F17L/F20/F20N
GF14XL/GF17XL
N15/N15D/N18/N18D
B10/B14/B14H
R5/R10/R20

Chapter 2 Periodic inspection

Contents

1. Before beginning work	2-1
2. Periodic inspection	2-2
2.1 Daily inspection	2-2
2.2 Three-month inspection	2-3
2.3 Six-month inspection	2-5
2.4 Three-year inspection	2-6
3. Applying the grease	2-7
3.1 T4L/T4LH/T5L/T5LH/T6L	2-8
3.2 T9/T9H/F10/F10H/F14/F14H/F17/F17L/F20/F20N/GF14XL/GF17XL	2-9
3.3 F8/F8L/F8LH	2-10
3.4 N15/N15D/N18/N18D	2-11
3.5 B10/B14/B14H	2-12

1. Before beginning work

Periodic inspection and maintenance are essential to ensure safe and efficient operation of YAMAHA robots. This Chapter describes the periodic inspection of the FLIP-X series. Before beginning the work, thoroughly read the safety precautions described below and the Safety Instructions to strictly observe the instructions.

■ Safety precautions



DANGER

IF THE INSPECTION OR MAINTENANCE PROCEDURE CALLS FOR OPERATION OF THE ROBOT, STAY OUT OF THE WORKING AREA OF THE ROBOT DURING OPERATION. KEEP WATCHING THE ROBOT MOVEMENT AND SURROUNDING AREA SO THAT THE OPERATOR CAN PRESS THE EMERGENCY STOP BUTTON IF ANY DANGER OCCURS.



WARNING

- THE ADJUSTMENT AND MAINTENANCE WORK WITH THE COVER REMOVED NEEDS THE SPECIAL KNOWLEDGE AND SKILL. IF UNSKILLED WORK PERSON PERFORMS SUCH WORK, THIS MAY INVOLVE RISK. THE ADJUSTMENT AND MAINTENANCE WORK MUST BE PERFORMED ONLY BY PERSONS WHO HAVE THE REQUIRED QUALIFICATIONS DESCRIBED IN "2. QUALIFICATION OF OPERATORS/WORKERS" IN SECTION 4.1 OF "SAFETY INSTRUCTIONS", WHILE REFERRING TO THIS MANUAL.
- WHEN THE ROBOT DOES NOT NEED TO BE OPERATED DURING ADJUSTMENT OR MAINTENANCE, ALWAYS TURN OFF THE CONTROLLER AND THE EXTERNAL SWITCH BOARD.
- WHEN YOU NEED TO TOUCH THE TERMINALS OR CONNECTORS ON THE OUTSIDE OF THE CONTROLLER DURING INSPECTION, ALWAYS FIRST TURN OFF THE CONTROLLER POWER SWITCH AND ALSO THE POWER SOURCE IN ORDER TO PREVENT POSSIBLE ELECTRICAL SHOCK.
- NEVER TOUCH INTERNAL PARTS OF THE CONTROLLER.
- WHEN ONLY MAKING ELECTRICAL INSPECTIONS AND REQUIRING NO MECHANICAL MOVEMENT OF THE ROBOT, KEEP THE EMERGENCY STOP BUTTON PRESSED.
- BE CAREFUL NOT TO NEGLECT TIGHTENING SCREWS OR BOLTS. IF ANY COVER IS NOT SECURED FIRMLY, THIS MAY CAUSE NOISE, COVER DROPPING AND FLYING, HAND ENTANGLEMENT IN DRIVE UNIT DURING TEACHING, OR BURN DUE TO HAND IN CONTACT WITH HOT SURFACE. SO, BE SURE TO TIGHTEN ALL THE SCREWS AND BOLTS SECURELY.
- BE SURE TO USE THE LUBRICANT SPECIFIED BY YOUR DISTRIBUTOR.
- BE SURE TO USE THE PARTS SPECIFIED BY YOUR DISTRIBUTOR WHEN REPLACING PARTS. TAKE SUFFICIENT CARE NOT TO ALLOW ANY FOREIGN MATTER TO CONTAMINATE THEM DURING ADJUSTMENT, PARTS REPLACEMENT OR REASSEMBLY.
- DO NOT MODIFY ANY PARTS ON THE ROBOT OR CONTROLLER. MODIFICATION MAY RESULT IN UNSATISFACTORY SPECIFICATIONS OR THREATEN OPERATOR SAFETY.
- WHEN ADJUSTMENT OR MAINTENANCE IS COMPLETE, RETIGHTEN THE BOLTS AND SCREWS SECURELY.
- PLACE A SIGN INDICATING THE ROBOT IS BEING ADJUSTED OR INSPECTED TO KEEP OTHERS FROM OPERATING THE CONTROLLER POWER SWITCH, PROGRAMMING BOX, HANDY TERMINAL, OR OPERATION PANEL. WHEN NECESSARY, INSTALL AN APPROPRIATE SWITCH KEY LOCK MECHANISM OR ARRANGE A WATCHER.



CAUTION

- Only qualified engineers who have the skill and license in accordance with the laws and regulations in each country are allowed to carry out the periodic inspection.
- Never attempt to perform inspection, adjustment, repair, or part replacement work of the robot and controller other than those described in this manual. Such work requires special knowledge and may involve risk.
- Before starting each adjustment work, thoroughly read this Chapter to fully understand its contents.
- If a safety enclosure has not yet been provided right after installation of the robot, rope off or chain off the movement area around the manipulator in place of a safety enclosure, and observe the following points.
 1. Use stable posts which will not fall over easily.
 2. The rope or chain should be easily visible by everyone around the robot.
 3. Place a conspicuous sign prohibiting the operator or other personnel from entering the movement area of the manipulator.
- To check the operation after the adjustment has been made, see "4.6.1 Trial operation" in the Safety Instructions.
- Be sure to wear safety gloves before starting the work. If you touch any steel material part with bare hands, this may cause rust.
- Be careful not to drop any screw or bolt during cover removal work.
- For details about cautions on controller, see the User's Manual for controller.

2. Periodic inspection

2.1 Daily inspection

The following is an inspection list that must be performed every day before and after operating the robot.

■ Inspection to be performed with the controller turned off

Step 1 Turn off the controller.

Step 2 Place a sign indicating the robot is being adjusted.

Place a sign indicating the robot is being inspected, to keep others from operating the controller switch.

Step 3 Perform the daily inspection.

Enter the safety enclosure and check the following points.

Checkpoints	Procedure	Remarks
Cables	Check for damage, dent and excessively tight bends.	<ul style="list-style-type: none">• Make the adjustment so that any stress is not applied to the cables.• If any damage is found, replace the defective cable according to the conditions. (See also "2.2 Robot cables" in Chapter 5 of the separate Installation Manual.)
Shutter	<ul style="list-style-type: none">• Check for scratches, dents, and excessively tight bends.• Check for flow-up (clearance).• Check the shutter top surface for contamination (*1).	See "5. Adjusting the shutter looseness" in Chapter 3. When the shutter replacement is needed, see "1. Replacing the shutter" in Chapter 4.
Ball screw, bearing	Check for unusual vibration or noise.	If any trouble is found, contact your distributor.
Motor	Check for unusual vibration and noise, and for abnormal temperature rise.	Check with the load factor monitor that the load factor is 100% or less. (*2)

*1: According to the robot working conditions, stripe marks caused by contamination may be produced on the shutter top surface close to the stop point. If this occurs, clean the shutter top surface with a cloth rag moistened with alcohol cleaning agent. If this trouble occurs frequently, contact your distributor.

*2: Some robot controller models cannot monitor the load factor.

■ Inspection to be performed with the controller turned on



WARNING

THE ROBOT CONTROLLER MUST BE INSTALLED OUTSIDE THE SAFETY ENCLOSURE, TO PREVENT A HAZARDOUS SITUATION IN WHICH YOU OR ANYONE ENTER THE SAFETY ENCLOSURE TO INSPECT THE CONTROLLER WHILE IT IS TURNED ON.

Step 1 Turn on the controller.

Check that no one is inside the safety enclosure, and then turn on the controller.

Step 2 Place a sign indicating the robot is being adjusted.

Place a sign indicating the robot is being inspected, to keep others from operating the controller, programming box or operation panel.

Step 3 Perform the daily inspection.

Check the following points from outside the safety enclosure.

Checkpoint	Procedure	Remarks
Safety enclosure	Check if the safety enclosure is in place. Check if emergency stop is triggered when the door is opened. Check if warning labels are affixed at the entrance and clearly visible.	
Emergency stop device	Press the emergency stop button to check if it works.	
Robot movement	Check for abnormal movement and excessive vibration and noise.	If any abnormal operation is found, contact your distributor.
Z-axis brake operation (*1)	Check if the brake works to stop the Z-axis from dropping more than 3mm from the stationary point.	If any abnormal operation is found, contact your distributor.

*1: Visually check the Z-axis movement when you press the emergency stop button from outside the safety enclosure and also when you turn off the controller.

■ Adjustment and parts replacement



WARNING

- AFTER INSPECTION, IF YOU NOTICE ANY ADJUSTMENT OR PARTS REPLACEMENT IS NEEDED, FIRST TURN OFF THE CONTROLLER AND THEN ENTER THE SAFETY ENCLOSURE TO PERFORM THE NECESSARY WORK.
- AFTER THE ADJUSTMENT OR REPLACEMENT WORK HAS BEEN COMPLETED, INSPECT THE CHECKPOINTS STATED IN "DAILY INSPECTION" IN THIS SECTION.
- IF THE REPAIR OR PART REPLACEMENT OF THE ROBOT OR CONTROLLER IS REQUIRED, CONTACT YOUR DISTRIBUTOR. SUCH WORK NEEDS THE SPECIAL KNOWLEDGE AND SKILL. SO, THE REPAIR OR PART REPLACEMENT WORK OF THE ROBOT OR CONTROLLER MUST BE PERFORMED ONLY BY PERSONS WHO HAVE THE REQUIRED QUALIFICATIONS DESCRIBED IN "2. QUALIFICATION OF OPERATORS/WORKERS" IN SECTION 4.1 OF "SAFETY INSTRUCTIONS".

2.2 Three-month inspection

Take the following precautions when performing 3-month inspection.



WARNING

WHEN THE BRAKE OF THE VERTICAL AXIS IS RELEASED, THE SLIDER AXIS MAY DROP, LEADING TO HAZARDOUS SITUATION. WHEN APPLYING THE GREASE TO THE VERTICAL AXIS PARTS, DO NOT RELEASE THE BRAKE.

■ Inspection to be performed with the controller turned off

Step 1 Turn off the controller.

Step 2 Place a sign indicating the robot is being adjusted.

Place a sign indicating the robot is being inspected, to keep others from operating the controller switch.

Step 3 Perform the inspection.

Enter the safety enclosure and check the following points.

Checkpoint	Procedure	Remarks										
Manipulator bolts and screws (Only for major bolts and screws exposed externally)	Check for looseness and tighten if necessary. (*1)											
Controller	Check for looseness at each terminal and connector on the panel.											
Ball screw, Linear guide	<ul style="list-style-type: none"> • Check for dirt or grime. If dirt or grime is found, clean the part. Apply grease after cleaning. • Apply grease if the items checked are dry or do not have enough grease. <table border="1"> <thead> <tr> <th colspan="2">Recommended grease</th> </tr> </thead> <tbody> <tr> <td>N18</td> <td>Daphne Eponex SR2 (Idemitsu)</td> </tr> <tr> <td rowspan="2">Other than N18</td> <td>Alvania grease S2 (Showa Shell)</td> </tr> <tr> <td>Alvania No.2 (Showa Shell)</td> </tr> <tr> <td rowspan="2">Common</td> <td>Daphne Eponex No. 2 (Idemitsu)</td> </tr> <tr> <td>LG2 (NSK) For Clean Specification</td> </tr> </tbody> </table>	Recommended grease		N18	Daphne Eponex SR2 (Idemitsu)	Other than N18	Alvania grease S2 (Showa Shell)	Alvania No.2 (Showa Shell)	Common	Daphne Eponex No. 2 (Idemitsu)	LG2 (NSK) For Clean Specification	See "3. Applying the grease" in this Chapter.
Recommended grease												
N18	Daphne Eponex SR2 (Idemitsu)											
Other than N18	Alvania grease S2 (Showa Shell)											
	Alvania No.2 (Showa Shell)											
Common	Daphne Eponex No. 2 (Idemitsu)											
	LG2 (NSK) For Clean Specification											
Shutter	<ul style="list-style-type: none"> • Check for looseness. • Check for flow-up (clearance). 	See "4. Adjusting shutter looseness" in Chapter 3.										

*1: Bolt tightening torque

Bolt size	Tightening torque (kgfcm)	Tightening torque (Nm)
M3 button head bolt	14	1.4
M3	20	2.0
M4	46	4.5
M5	92	9.0
M6	156	15.3
M8	380	37
M10	720	71
M12	1310	128



CAUTION

If the grease recommended by YAMAHA is not used, this may cause the service life of the ball screw or linear guide to shorten.

■ Inspection to be performed with the controller turned on



WARNING

THE ROBOT CONTROLLER MUST BE INSTALLED OUTSIDE THE SAFETY ENCLOSURE, TO PREVENT A HAZARDOUS SITUATION IN WHICH YOU OR ANYONE ENTER THE SAFETY ENCLOSURE TO INSPECT THE CONTROLLER WHILE IT IS TURNED ON.



WARNING

- BODILY INJURY MAY OCCUR FROM COMING INTO CONTACT WITH THE FAN WHILE IT IS ROTATING.
- WHEN REMOVING THE FAN COVER FOR INSPECTION, FIRST TURN OFF THE CONTROLLER AND MAKE SURE THE FAN HAS STOPPED.

Step 1 Turn on the controller.

Check that no one is inside the safety enclosure, and then turn on the controller.

Step 2 Place a sign indicating the robot is being adjusted.

Place a sign indicating the robot is being inspected, to keep others from operating the controller, programming box or operation panel.

Step 3 Perform the inspection.

Check the following points from outside the safety enclosure.

Checkpoint	Procedure
Cooling fan at rear of controller	<ul style="list-style-type: none"> • Check if the fan rotates normally. • Check if objects blocking the fan are located and remove if any are found. • Check for abnormal noise from the rotating fan. If abnormal noise is heard, visually check and remove the cause. If no cause is found, contact your distributor . • Check for dust on the fan cover. Remove and clean if necessary.

■ Adjustment and parts replacement



WARNING

- AFTER INSPECTION, IF YOU NOTICE ANY ADJUSTMENT OR PARTS REPLACEMENT IS NEEDED, FIRST TURN OFF THE CONTROLLER AND THEN ENTER THE SAFETY ENCLOSURE TO PERFORM THE NECESSARY WORK.
- AFTER THE ADJUSTMENT OR REPLACEMENT WORK HAS BEEN COMPLETED, INSPECT THE CHECKPOINTS STATED IN "DAILY INSPECTION" IN THIS SECTION.
- IF THE REPAIR OR PART REPLACEMENT OF THE ROBOT OR CONTROLLER IS REQUIRED, CONTACT YOUR DISTRIBUTOR. SUCH WORK NEEDS THE SPECIAL KNOWLEDGE AND SKILL. SO. THE REPAIR OR PART REPLACEMENT WORK OF THE ROBOT OR CONTROLLER MUST BE PERFORMED ONLY BY PERSONS WHO HAVE THE REQUIRED QUALIFICATIONS DESCRIBED IN "2. QUALIFICATION OF OPERATORS/WORKERS" IN SECTION 4.1 OF "SAFETY INSTRUCTIONS".

2.3 Six-month inspection

Take the following precautions when performing 6-month inspection.



WARNING

WHEN THE BRAKE OF THE VERTICAL AXIS IS RELEASED, THE SLIDER AXIS MAY DROP, LEADING TO HAZARDOUS SITUATION. WHEN APPLYING THE GREASE TO THE VERTICAL AXIS PARTS, DO NOT RELEASE THE BRAKE.

■ Inspection to be performed with the controller turned off

Step 1 Turn off the controller.

Step 2 Place a sign indicating the robot is being adjusted.

Place a sign showing that the robot is being inspected, to keep others from operating the controller switch.

Step 3 Perform the inspection.

Enter the safety enclosure and check the following points.

Checkpoint	Procedure	Remarks									
Major bolts and screws on exterior of robot main unit	Check for looseness and tighten if necessary. (*1)										
Ball screw and linear guide	<ul style="list-style-type: none"> Check for looseness in the ball screw and linear guide. Tighten if necessary. Check for vibration during operation. Tighten drive section, and X and Y axis installation bolts if necessary. Check for wear and backlash. If any abnormality is found, contact your distributor. 	If problem is not solved or wear and backlash are found, please contact your distributor.									
Controller	<ul style="list-style-type: none"> Check for loose terminals. Check for loose connectors. 										
Application of grease to ball screw/nut and linear guide	Apply the grease every 6 months. <table border="1" style="margin-left: 20px;"> <thead> <tr> <th colspan="2">Recommended grease</th> </tr> </thead> <tbody> <tr> <td>N18</td> <td>Daphne Eponex SR2 (Idemitsu)</td> </tr> <tr> <td rowspan="2">Other than N18</td> <td>Alvania grease S2 (Showa Shell)</td> </tr> <tr> <td>Daphne Eponex No. 2 (Idemitsu)</td> </tr> <tr> <td>Common</td> <td>LG2 (NSK) For Clean Specification</td> </tr> </tbody> </table>	Recommended grease		N18	Daphne Eponex SR2 (Idemitsu)	Other than N18	Alvania grease S2 (Showa Shell)	Daphne Eponex No. 2 (Idemitsu)	Common	LG2 (NSK) For Clean Specification	See "3. Applying the grease" in this Chapter.
Recommended grease											
N18	Daphne Eponex SR2 (Idemitsu)										
Other than N18	Alvania grease S2 (Showa Shell)										
	Daphne Eponex No. 2 (Idemitsu)										
Common	LG2 (NSK) For Clean Specification										
Belt	<ul style="list-style-type: none"> Check the timing belt for fault (scratch or crack). Check the tension of the timing belt. 	See Chapter 3, Adjustment.									
Slider	Check for unusual wear or damage.	<ul style="list-style-type: none"> If the friction is the cause of the trouble, make the adjustment so that the interference between the mating part and slider is eliminated. If the slider is broken, contact your distributor. 									
Resin slider	<ol style="list-style-type: none"> Check for backlash due to wear Check for dirt or contamination. 	<ol style="list-style-type: none"> Replace the resin slider. (When replacing, contact your distributor.) Perform the cleaning. 									
Bushing	<ul style="list-style-type: none"> Check for unusual sound or vibration. Check for backlash due to wear Check that the clearance to the ball screw is wide. 	When replacing, see "7. Replacing the bushings" in Chapter 4									
Wire	<ol style="list-style-type: none"> Check for scratch or fray. Check for looseness. 	<ol style="list-style-type: none"> Replace the wire. (When replacing, contact your distributor.) Adjust the wire tension. (When replacing, contact your distributor.) 									
Resin pulley	Check for backlash due to wear	Replace the pulley. (When replacing, contact your distributor.)									
Insert	<ul style="list-style-type: none"> Check that the positioning is correct during operation. Check for unusual noise during operation. 	See "3. Replacing the insert" in Chapter 4.									



CAUTION

If the grease recommended by YAMAHA is not used, this may cause the service life of the ball screw or linear guide to shorten.

***1: Bolt tightening torque**

Bolt size	Tightening torque (kgfcm)	Tightening torque (Nm)
M3 button head bolt	14	1.4
M3	20	2.0
M4	46	4.5
M5	92	9.0
M6	156	15.3
M8	380	37
M10	720	71
M12	1310	128

■ Inspection to be performed with the controller turned on

**WARNING**

THE ROBOT CONTROLLER MUST BE INSTALLED OUTSIDE THE SAFETY ENCLOSURE, TO PREVENT A HAZARDOUS SITUATION IN WHICH YOU OR ANYONE ENTER THE SAFETY ENCLOSURE TO INSPECT THE CONTROLLER WHILE IT IS TURNED ON.

**WARNING**

- BODILY INJURY MAY OCCUR FROM COMING INTO CONTACT WITH THE FAN WHILE IT IS ROTATING.
- WHEN REMOVING THE FAN COVER FOR INSPECTION, FIRST TURN OFF THE CONTROLLER AND MAKE SURE THE FAN HAS STOPPED.

Step 1 Turn on the controller.

Check that no one is inside the safety enclosure, and then turn on the controller.

Step 2 Place a sign indicating the robot is being adjusted.

Place a sign indicating the robot is being inspected, to keep others from operating the controller, programming box or operation panel.

Step 3 Perform the inspection.

Check the following points from outside the safety enclosure.

Checkpoint	Procedure
Cooling fan at rear of controller	<ul style="list-style-type: none"> • Check if the fan rotates normally. • Check if objects blocking the fan are located and remove if any are found. • Check for abnormal noise from the rotating fan. If abnormal noise is heard, visually check and remove the cause. If no cause is found, contact your distributor . • Check for dust on the fan cover. Remove and clean if necessary.

■ Adjustment and parts replacement

**WARNING**

- AFTER INSPECTION, IF YOU NOTICE ANY ADJUSTMENT OR PARTS REPLACEMENT IS NEEDED, FIRST TURN OFF THE CONTROLLER AND THEN ENTER THE SAFETY ENCLOSURE TO PERFORM THE NECESSARY WORK.
- AFTER THE ADJUSTMENT OR REPLACEMENT WORK HAS BEEN COMPLETED, INSPECT THE CHECKPOINTS STATED IN "DAILY INSPECTION" IN THIS SECTION.
- IF THE REPAIR OR PART REPLACEMENT OF THE ROBOT OR CONTROLLER IS REQUIRED, CONTACT YOUR DISTRIBUTOR. SUCH WORK NEEDS THE SPECIAL KNOWLEDGE AND SKILL. SO, THE REPAIR OR PART REPLACEMENT WORK OF THE ROBOT OR CONTROLLER MUST BE PERFORMED ONLY BY PERSONS WHO HAVE THE REQUIRED QUALIFICATIONS DESCRIBED IN "2. QUALIFICATION OF OPERATORS/WORKERS" IN SECTION 4.1 OF "SAFETY INSTRUCTIONS".

2.4 Three-year inspection

Inspect the following points once every three years, and contact us if any problem is found. Set an earlier inspection interval if parts are subject to long-term or frequent usage.

Checkpoint	Procedure	Remarks
Ball screw nut sections and linear guides	Check for wear and looseness in the ball screw, nut and linear guide.	If any abnormality is found, contact your distributor.

3. Applying the grease

To apply the grease in accordance with the periodic inspection, follow the steps below. Before applying the grease, thoroughly read the cautions stated in the Safety Guide and "Before beginning work" in this Chapter to strictly observe the instructions.

When applying grease to the ball screws and linear guide, take the following precautions.



WARNING

PRECAUTIONS WHEN HANDLING GREASE:

- INFLAMMATION MAY OCCUR IF THIS GETS IN THE EYES.
BEFORE HANDLING THE GREASE, WEAR YOUR SAFETY GOGGLES TO ENSURE THE GREASE WILL NOT COME IN CONTACT WITH THE EYES.
- INFLAMMATION MAY OCCUR IF THE GREASE COMES INTO CONTACT WITH SKIN. BE SURE TO WEAR PROTECTIVE GLOVES TO PREVENT CONTACT WITH SKIN.
- DO NOT TAKE ORALLY OR EAT. (EATING WILL CAUSE DIARRHEA AND VOMITING.)
- HANDS AND FINGERS MIGHT BE CUT WHEN OPENING THE CONTAINER, SO USE PROTECTIVE GLOVES.
- KEEP OUT OF THE REACH OF CHILDREN.
- DO NOT HEAT THE GREASE OR PLACE NEAR AN OPEN FLAME SINCE THIS COULD LEAD TO SPARKS AND FIRES.

EMERGENCY TREATMENT:

- IF THIS GREASE GETS IN THE EYES, WASH LIBERALLY WITH PURE WATER FOR ABOUT 15 MINUTES AND CONSULT A PHYSICIAN FOR TREATMENT.
- IF THIS GREASE COMES IN CONTACT WITH THE SKIN, WASH AWAY COMPLETELY WITH SOAP AND WATER.
- IF TAKEN INTERNALLY, DO NOT INDUCE VOMITING BUT PROMPTLY CONSULT A PHYSICIAN FOR TREATMENT.



WARNING

DISPOSING OF GREASE AND THE CONTAINER:

- PROPER DISPOSAL IS COMPULSORY UNDER FEDERAL, STATE AND LOCAL REGULATIONS. TAKE APPROPRIATE MEASURES IN COMPLIANCE WITH LEGAL REGULATIONS.
- DO NOT PRESSURIZE THE EMPTY CONTAINER. PRESSURIZING MAY CAUSE THE CONTAINER TO RUPTURE.
- DO NOT ATTEMPT TO WELD, HEAT UP, DRILL HOLES OR CUT THIS CONTAINER. THIS MIGHT CAUSE THE CONTAINER TO EXPLODE AND THE REMAINING MATERIALS INSIDE IT TO IGNITE.



WARNING

WHEN THE BRAKE OF THE VERTICAL AXIS IS RELEASED, THE SLIDER AXIS MAY DROP, LEADING TO HAZARDOUS SITUATION. WHEN APPLYING THE GREASE TO THE VERTICAL AXIS PARTS, DO NOT RELEASE THE BRAKE.



CAUTION

Be sure to wear safety gloves before starting the work. If you touch any steel material part with bare hands, this may cause rust.

3.1 T4L/T4LH/T5L/T5LH/T6L

Prepare appropriate Phillips screwdriver and brush (for grease application).

Step 1 Turn off the controller power.

Step 2 Place a sign indicating the robot is being adjusted.

Place a sign indicating the robot is being adjusted, to keep others from operating the controller or operation panel.

Step 3 Enter the safety enclosure.

Step 4 Remove the screws (2) from one side.

Remove the screws (2) from one side of the screws securing both ends of the shutter.



CAUTION

At this time, do not remove the cover completely.

Step 5 Turn over the shutter from the side where the screws have been removed.



CAUTION

When turning over the shutter, carefully handle it so that the shutter surface is not scratched.

Step 6 Wipe off the contaminated grease.

First, wipe off the contaminated grease with a clean cloth rag.

Step 7 Apply the grease.

Apply an adequate amount of grease to the ball screw or linear guide so that it does not scatter surroundings.



CAUTION

For the T4L/T4LH robot, the brush insertion portion is narrow. So, apply the grease with a small brush.

23301-A1-00

Step 8 Spread the grease.

Move the slider back and forth to spread the grease.



CAUTION

Do not put your finger in the slider movement range to prevent your finger from being caught in if the slider is moved by hand accidentally.

Step 9 Reattach the shutter to its original position.



NOTE

For details about how to adjust the shutter, see "4. Adjusting shutter looseness" in Chapter 3.

Step 7 Applying the grease



Applying grease to the ball screw

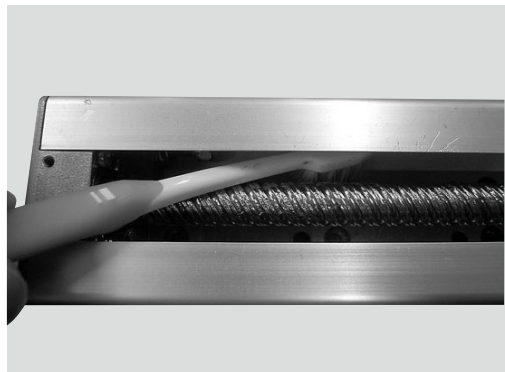

Applying grease to the linear guide

Chapter 3

Adjustment

Contents

1. Adjusting the alignment (B10/B14/B14H)	3-1
2. Adjusting the timing belt tension (B10/B14/B14H)	3-2
2.1 Adjusting the drive belt tension	3-3
2.2 Adjusting the speed reduction belt tension	3-4
3. Adjusting the timing belt tension (F20N)	3-6
3.1 Installing and removing the cover	3-6
3.1.1 Stroke cover	3-6
3.1.2 Belt cover	3-8
3.1.3 Motor cover	3-9
3.2 Adjusting the timing belt tension	3-10
4. Adjusting shutter looseness (T4L/T4LH/T5L/T5LH/T6L)	3-11

4. Adjusting shutter looseness (T4L/T4LH/T5L/T5LH/T6L)

The shutter may elongate with continued use. In such cases, adjust as follows.



CAUTION

Be sure to wear safety gloves before starting the work. If you touch any steel material part with bare hands, this may cause rust.

Prepare an appropriate Phillips screwdriver.



CAUTION

When the robot is installed vertically, slowly move the robot at a JOG speed to check the position where the shutter becomes loose mostly before entering the safety enclosure.

Step 1 Turn off the controller power.

Step 2 Place a sign indicating the robot is being adjusted.

Place a sign indicating the robot is being adjusted, to keep others from operating the controller or operation panel.

Step 3 Enter the safety enclosure.

Step 4 Loosen the screw lightly.

Lightly loosen the screws (2) securing the shutter on the end block side. (At this time, do not remove the screws.)

Step 5 Secure the shutter.

While stretching the shutter by fingers, tighten the screws to secure the shutter so that it does not become loose.



CAUTION

Do not press down on the shutter with excessive force. Pressing down hard on the shutter may cause the shutter to warp.

Adjusting the looseness



53303-A1-00

Chapter 4 Replacement

Contents

1. Replacing the shutter (T4L/T4LH/T5L/T5LH/T6L)	4-1
2. Replacing the motor	4-3
2.1 T4L/T4LH/T5L/T5LH/T6L	4-3
2.2 F8/F8L/F8LH	4-5
2.3 B10/B14/B14H	4-8
2.4 F20N	4-9
2.5 N15/N15D/N18/N18D	4-11
2.6 GF14XL/GF17XL	4-15
2.6 Checking the grid position	4-17
3. Replacing the insert (T4L/T4LH/T5L/T5LH/T6L)	4-18
4. Replacing the drive and speed reduction belts (B10/B14/B14H)	4-20
4.1 Replacing the drive belt	4-20
4.2 Replacing the speed reduction belt	4-22
5. Replacing the slider	4-23
5.1 B10/B14/B14H	4-23
5.2 F20N	4-24
6. Replacing the coupling (GF14XL/GF17XL)	4-25
7. Replacing the bushings (GF14XL/GF17XL)	4-27
8. Maintenance parts	4-28
8.1 Consumable parts	4-28

1. Replacing the shutter (T4L/T4LH/T5L/T5LH/T6L)

When the shutter needs to be replaced, follow the steps below.



WARNING

- BEFORE STARTING THE REPLACEMENT WORK, BE SURE TO DISCONNECT THE ROBOT FROM THE CONTROLLER OR TURN OFF THE CONTROLLER POWER. IF THE ROBOT OPERATES DURING THE REPLACEMENT WORK, THIS MAY CAUSE SERIOUS ACCIDENT.
- THE REPLACEMENT WORK WITH THE COVER REMOVED MUST BE PERFORMED ONLY BY PERSONS WHO HAVE THE REQUIRED QUALIFICATIONS DESCRIBED IN "2. QUALIFICATION OF OPERATORS/WORKERS" IN SECTION 4.1 OF "SAFETY INSTRUCTIONS".
- BE CAREFUL NOT TO NEGLECT TIGHTENING SCREWS OR BOLTS. IF ANY COVER IS NOT SECURED FIRMLY, THIS MAY CAUSE NOISE, COVER DROPPING AND FLYING, HAND ENTANGLEMENT IN DRIVE UNIT DURING TEACHING, OR BURN DUE TO HAND IN CONTACT WITH HOT SURFACE. SO, BE SURE TO TIGHTEN ALL THE SCREWS AND BOLTS SECURELY.



CAUTION

- Be sure to wear safety gloves before starting the work. If you touch any steel material part with bare hands, this may cause rust.
- Be careful not to drop any screw or bolt during cover removal work.

Step 1 Turn off the controller power.

Step 2 Place a sign indicating the robot is being adjusted.

Place a sign indicating the robot is being adjusted, to keep others from operating the controller or operation panel.

Step 3 Enter the safety enclosure.

Step 4 Remove the slider cover.

Remove the screws (4) securing the slider cover and remove the slider cover.

53401-A1-00

Step 5 Remove the screws.

Remove the screws (2 each) securing the shutter from the end block and motor.

53402-A1-00

Step 6 Pull out the shutter.

Pull out the shutter from the shutter passing portion.

Step 4 Removing the slider cover

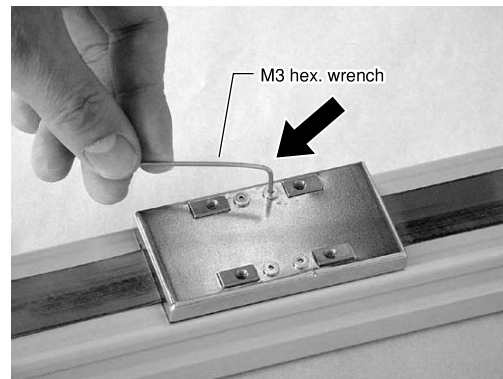

Step 5 Removing the shutter mounting screws

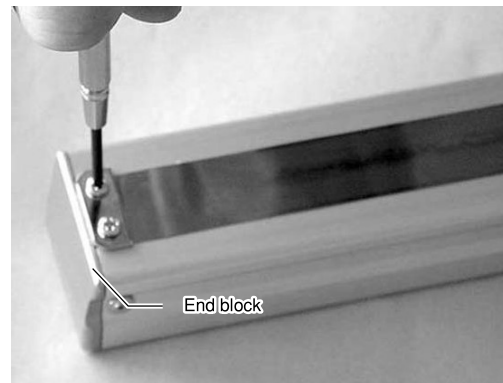

Step 7 Pass a new shutter.

53403-A1-00

Step 8 Reinstall the shutter and the slider cover using the reverse of the above procedure.**NOTE**

Do not fully tighten the screws to secure the shutter on the end block side at this time. Fully tighten these screws after adjusting for shutter looseness in Step 9.

Step 9 Secure the shutter.

Tighten the screws while pulling on the shutter with your fingers so that there is no looseness in the shutter.

53404-A1-00

**CAUTION**

Do not press down on the shutter with excessive force. Pressing down hard on the shutter may cause the shutter to warp.

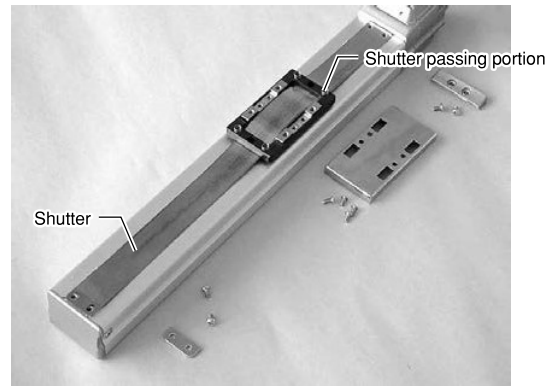
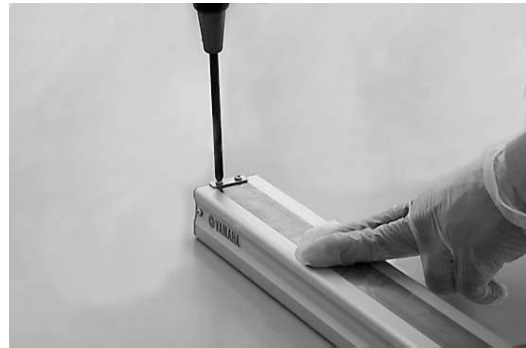
Step 7 Replacing the shutter**Step 9** Adjusting the shutter looseness

2. Replacing the motor

2.1 T4L/T4LH/T5L/T5LH/T6L



WARNING

- BEFORE STARTING THE REPLACEMENT WORK, BE SURE TO DISCONNECT THE ROBOT FROM THE CONTROLLER OR TURN OFF THE CONTROLLER POWER. IF THE ROBOT OPERATES DURING THE REPLACEMENT WORK, THIS MAY CAUSE SERIOUS ACCIDENT.
- THE REPLACEMENT WORK WITH THE COVER REMOVED MUST BE PERFORMED ONLY BY PERSONS WHO HAVE THE REQUIRED QUALIFICATIONS DESCRIBED IN "2. QUALIFICATION OF OPERATORS/WORKERS" IN SECTION 4.1 OF "SAFETY INSTRUCTIONS".
- BE CAREFUL NOT TO NEGLECT TIGHTENING SCREWS OR BOLTS. IF ANY COVER IS NOT SECURED FIRMLY, THIS MAY CAUSE NOISE, COVER DROPPING AND FLYING, HAND ENTANGLEMENT IN DRIVE UNIT DURING TEACHING, OR BURN DUE TO HAND IN CONTACT WITH HOT SURFACE. SO, BE SURE TO TIGHTEN ALL THE SCREWS AND BOLTS SECURELY.



CAUTION

- Since a positional shift occurs after replacing the motor, return-to-origin must be performed again and the point data must be re-specified. When removing the parts, check and mark the part positions versus each other so you can correctly reassemble the parts later.
- Be sure to wear safety gloves before starting the work. If you touch any steel material part with bare hands, this may cause rust.
- Be careful not to drop any screw or bolt during cover removal work.

Step 1 Turn off the controller power.

Step 2 Place a sign indicating the robot is being adjusted.

Place a sign indicating the robot is being adjusted, to keep others from operating the controller or operation panel.

Step 3 Enter the safety enclosure.

Step 4 Remove the parts securing the shutter.

Remove the M4 screws (2) screws securing the shutter from each of the end block and motor sides.

53413-A1-00

Step 5 Remove the cover stroke.

Remove the M4 screws (2) screws securing the cover stroke from each of the left and right.

53414-A1-00

Step 4 Removing the parts securing the shutter

Parts securing the shutter
(End block side)
M4 screw, 2 pcs.

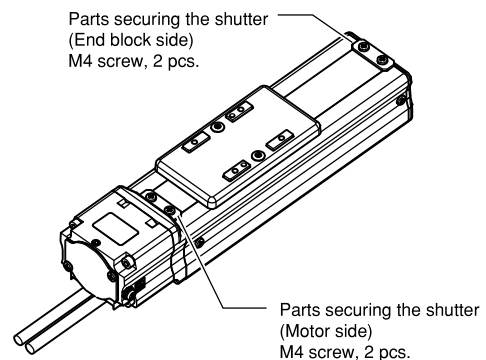

Parts securing the shutter
(Motor side)
M4 screw, 2 pcs.

Step 5 Removing the cover stroke

M4 screws securing
the cover stroke

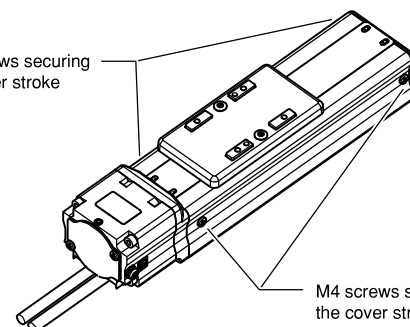

M4 screws securing
the cover stroke

Step 6 Remove the bolts securing the motor.

Remove the M5 bolts (2) bolts securing the motor.

53415-A1-00

Step 7 Remove the motor.

53416-A1-00

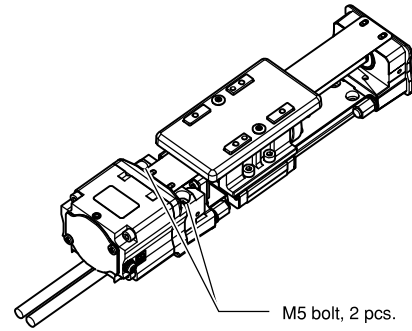
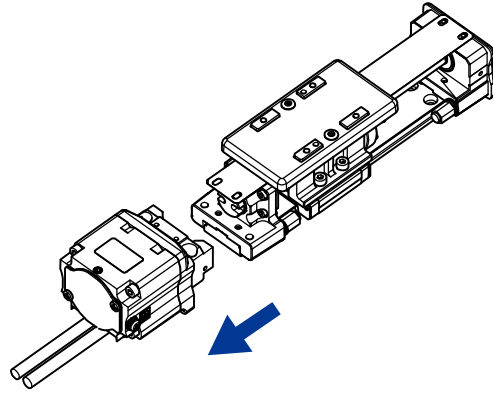
Step 8 Install a new motor.**Step 9** Assemble in the reverse order of disassembly (Step 6 → Step 4).**Step 6** Removing the bolts securing the motor**Step 7** Removing the motor

3. Replacing the insert (T4L/T4LH/T5L/T5LH/T6L)



WARNING

- BEFORE STARTING THE REPLACEMENT WORK, BE SURE TO DISCONNECT THE ROBOT FROM THE CONTROLLER OR TURN OFF THE CONTROLLER POWER. IF THE ROBOT OPERATES DURING THE REPLACEMENT WORK, THIS MAY CAUSE SERIOUS ACCIDENT.
- THE REPLACEMENT WORK WITH THE COVER REMOVED MUST BE PERFORMED ONLY BY PERSONS WHO HAVE THE REQUIRED QUALIFICATIONS DESCRIBED IN "2. QUALIFICATION OF OPERATORS/WORKERS" IN SECTION 4.1 OF "SAFETY INSTRUCTIONS".
- BE CAREFUL NOT TO NEGLECT TIGHTENING SCREWS OR BOLTS. IF ANY COVER IS NOT SECURED FIRMLY, THIS MAY CAUSE NOISE, COVER DROPPING AND FLYING, HAND ENTANGLEMENT IN DRIVE UNIT DURING TEACHING, OR BURN DUE TO HAND IN CONTACT WITH HOT SURFACE. SO, BE SURE TO TIGHTEN ALL THE SCREWS AND BOLTS SECURELY.



CAUTION

- Be sure to wear safety gloves before starting the work. If you touch any steel material part with bare hands, this may cause rust.
- Be careful not to drop any screw or bolt during cover removal work.

4

Replacement

Step 1 Turn off the controller power.

Step 2 Place a sign indicating the robot is being adjusted.

Place a sign indicating the robot is being adjusted, to keep others from operating the controller or operation panel.

Step 3 Enter the safety enclosure.

Step 4 Remove the parts securing the shutter.

Remove the M4 screws (2) securing the shutter from each of the end block and motor sides.

53417-A1-00

Step 5 Remove the cover stroke.

Remove the M4 screws (2) securing the cover stroke from each of the left and right.

53418-A1-00

Step 6 Remove the bolts securing the motor.

Remove the M5 bolts (2) securing the motor.

53419-A1-00

Step 4 Removing the parts securing the shutter

Parts securing the shutter
(End block side)
M4 screw, 2 pcs.

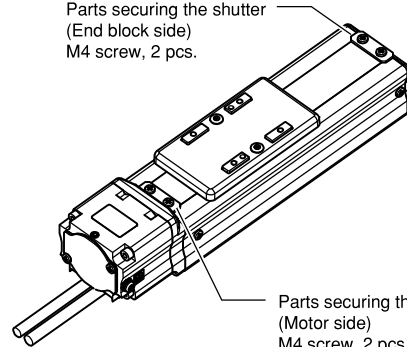

Parts securing the shutter
(Motor side)
M4 screw, 2 pcs.

Step 5 Removing the cover stroke

M4 screws securing
the cover stroke

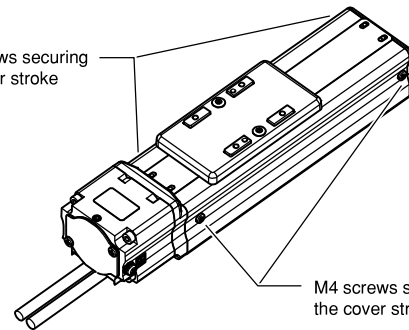

M4 screws securing
the cover stroke

Step 6 Removing the bolts securing the motor

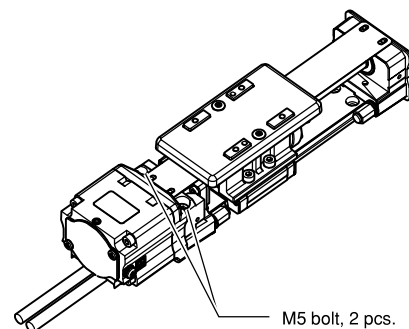

M5 bolt, 2 pcs.

Step 7 Remove the insert.

53420-A1-00

Step 7 Removing the insert

Step 8 Install a new insert.

Step 9 Assemble in the reverse order of disassembly (Step 6 → Step 4).

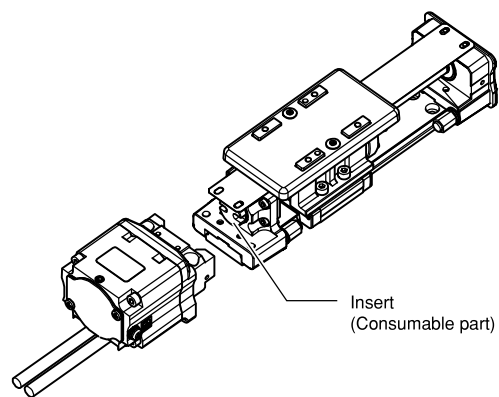

8. Maintenance parts

8.1 Consumable parts

■ T4L/T4LH

Part name	Part number		Remarks
Shutter	KDC-M229J-xxx	SHUTTER 1	50st to 400st
Insert	KDC-M2243-xxx	INSERT	Coupling resin part
Slider	KX1-M22L1-xxx	SLIDER	Slider resin part

■ T5L/T5LH

Part name	Part number		Remarks
Shutter	KDD-M229J-xxx	SHUTTER 1	50st to 800st
Insert	KDD-M2243-xxx	INSERT	Coupling resin part
Slider	KX2-M22L1-xxx	SLIDER	Slider resin part

■ T6L

Part name	Part number		Remarks
Shutter	KDE-M229J-xxx	SHUTTER 1	50st to 800st
Insert	KDD-M2243-xxx	INSERT	Coupling resin part
Slider	KX3-M22L1-xxx	SLIDER	Slider resin part

■ B10

Part name	Part number		Remarks
Belt	KY1-M225E-xxx	BELT	Motor drive unit
	KY1-M225F-xxx	BELT, STROKE	150 to 2250 (Movable part)
	KY1-M225G-xxx	BELT, STROKE	200 to 2500 (Movable part)

■ B14

Part name	Part number		Remarks
Belt	KY1-M225E-xxx	BELT	Motor drive unit
	KY2-M225F-xxx	BELT, STROKE	150 to 3050 (Movable part)
	KY2-M225G-xxx	BELT, STROKE	200 to 3000 (Movable part)

■ B14H

Part name	Part number		Remarks
Belt	KY1-M225E-xxx	BELT	Motor drive unit
	KY2-M225F-xxx	BELT, STROKE	150 to 3050 (Movable part)
	KY2-M225G-xxx	BELT, STROKE	200 to 3000 (Movable part)

■ GF14XL

Part name	Part number		Remarks
Bushing	KED-M229F-xxx	BUSH	Ball Screw Support Part. Replace for every three years or for 10000km.

■ GF17XL

Part name	Part number		Remarks
Bushing	KEE-M229F-xxx	BUSH	Ball Screw Support Part. Replace for every three years or for 10000km.

Chapter 5

Wiring specifications

Contents

1. AC servo motor specifications	5-1
1.1 AC servo motor termination (T4L/T5L)	5-1
1.2 AC servo motor termination (T4LH/T5LH/T6L)	5-2
1.3 AC servo motor termination (F8/F8L/F8LH)	5-3
1.4 AC servo motor termination (T9/T9H/F10/F10H/F14/F14H/F17/F17L/F20)	5-4
1.5 AC servo motor termination (B10/B14/B14H/R5/R10/R20/F20N/N15/N18)	5-5
1.6 Brake cable specifications	5-6
2. Robot cables (DC24V specifications)	5-7
(T4L/T5L)	
2.1 Single-axis robot cables	5-7
2.1.1 Cables for ERCD	5-7
3. Robot cables (200V specifications)	5-8
(T4LH/T5LH/T6L/T9/T9H/F8/F8L/F8LH/F10/F10H/F14/F14H/F17/F17L/F20/B10/ B14/B14H/R5/R10/R20)	
3.1 Single-axis robot cables	5-8
3.1.1 Cables for TS-X	5-8
3.1.2 Cables for SR1-X	5-9
3.1.3 Cables for RDV-X (robot with brake and sensor)	5-10
3.1.4 Cables for RDV-X (robot without brake)	5-12
3.2 Multi-robot cables	5-13
3.2.1 Cables for single-axis multi-robot	5-13
3.2.2 Cables for two-axis multi-robot	5-14
4. Machine harness	5-20
4.1 N15/N15D/N18/N18D	5-20
4.2 F20N	5-21
5. Cables models	5-22
5.1 Single-axis robot cables	5-22
5.2 Multi-robot cables	5-23

1. AC servo motor specifications

1.1 AC servo motor termination (T4L/T5L)

■ Connector specifications

No.	Parts	Type No.	Maker	Qty	Notes
1	Servo motor			1	
2	Receptacle housing	SMR-09V-B	JST	1	CN1 (9 polarities)
3	Pin contact	SYM-001T-P0.6	JST	9	CN1
4	Receptacle housing	5557-04R	MOLEX	1	CN2 (4 polarities)
5	Receptacle	5556T	MOLEX	4	CN2

■ Connector wiring

Connector	Pin No.	Signal	Wire Color	Connection	
CN1	1	S2	Yellow		CN1 1
	2	S4	Blue		2
	3	S1	Red		3
	4	S3	Black		4
	5	R1	White		5
	6	R2	Green		6
	7	JP1	Red		7
	8	JP2	Red		8
	9	Shield	Grey (Heat shrinkable tube)		9
CN2	1	U	Red		CN2 1
	2	V	White		2
	3	W	Black		3
	4	PE	Yellow/Green		4

T4L/T5L

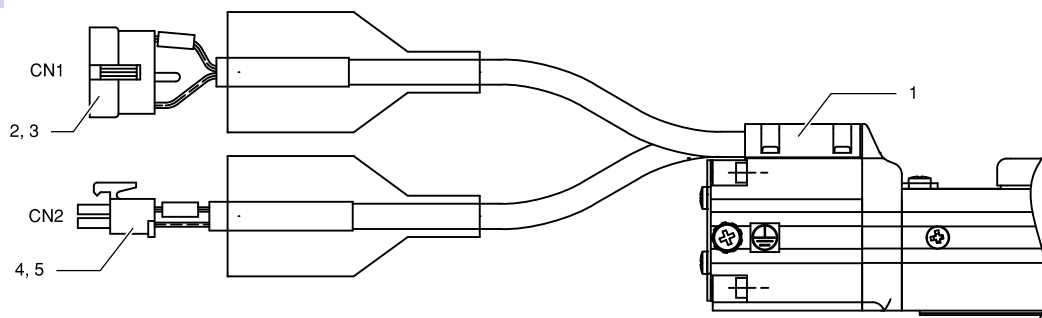

53501-A1-00

* This Fig. shows the T4L robot.

1.2 AC servo motor termination (T4LH/T5LH/T6L)

■ Connector specifications

No.	Parts	Type No.	Maker	Qty	Notes
1	Servo motor			1	
2	Receptacle housing	SMR-07V-B	JST	1	CN1 (7 polarities)
3	Pin contact	SYM-001T-P0.6	JST	7	CN1
4	Receptacle housing	5557-04R	MOLEX	1	CN2 (4 polarities)
5	Receptacle	5556T	MOLEX	4	CN2

■ Connector wiring

Connector	Pin No.	Signal	Wire Color	Connection	
CN1	1	S2	Yellow		CN1 1
	2	S4	Blue		2
	3	S1	Red		3
	4	S3	Black		4
	5	R1	White		5
	6	R2	Green		6
	7	Shield	Grey (Heat shrinkable tube)		7
CN2	1	U	Red		CN2 1
	2	V	White		2
	3	W	Black		3
	4	PE	Yellow/Green		4

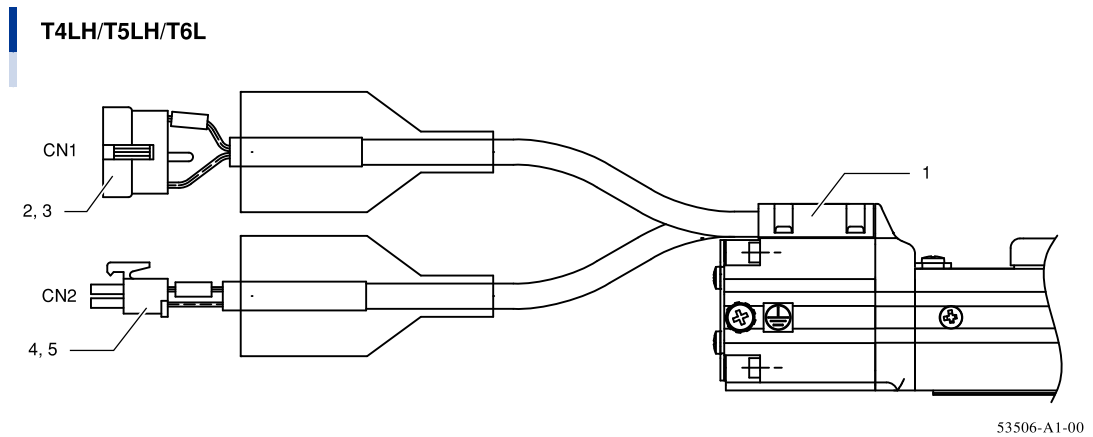

* This Fig. shows the T4LH robot.